

Horizontal Lever Stand

LH-220 without Distance Meter

LH-220S with Distance Meter

- Tension and compression testing
- Horizontal positioning is easy to control
- Lever action allows for rapid testing
- Large work area accommodates a wide variety of samples
- Stroke 4"
- Maximum load 220 lbf (100 kgf)



The LH-220/LH-220S Horizontal Manual Lever Test Stands provide maximum versatility and reliability. LH-220S is equipped with a precision digital distance meter. The stands will accommodate any of the standard range Imada force gauges. The large working platform accommodates a wide variety of samples—ideal for push or pull tests. The stand is unaffected by gravity and does not employ a return spring, making it perfect for crimp testing and other applications. The lever action provides for quick, consistent tests. Threaded feet enable the stand to be easily levelled.

AP-002 Adapter Plate is available to mount most other force gauges to IMADA test stands.

| Distance Meter Specifications | |
|-------------------------------|---|
| Display | Push button for inch/mm, zero set and on/off |
| Resolution | 0.0005"/0.01mm |
| Accuracy | 0.1% of reading or 0.005"/0.1mm, whichever is greater |

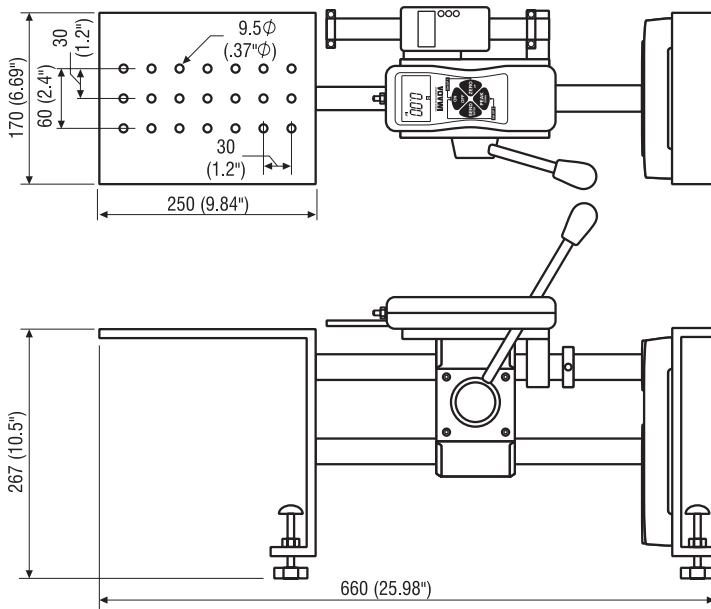

Force gauge sold separately Specifications subject to change without notice.