



MADE IN
USA

APS SERIES Power Transducers

Applications

Grinding and Milling Control

- Measure grinder horsepower; optimize feed rates.

Viscosity Control

- Continuously calculate mixer kW draw; monitor viscosity without entering vessel.

Tool Monitoring and Jam Protection

- Measure drive motor HP to determine tool travel or contact with work.
- Monitor motor horsepower to provide an indication of motor jams.

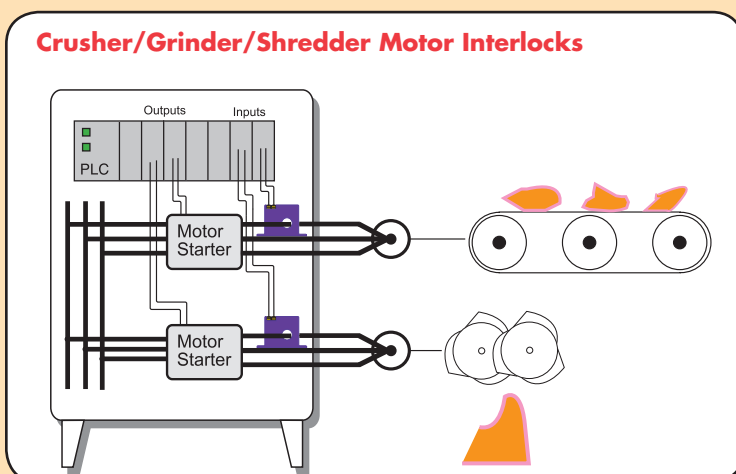

APS Series kWH Power Transducers offer an inexpensive way to measure kWH on single- and three-phase balanced loads. The APS Series constantly measures motor power consumption, which is proportional to the amount of work being done and an indication of the motor load. Ideal for mixing, grinding, machining and pumping applications where power measurement is needed, the APS Series includes a CT, voltage sensor and output signal conditioner in a single package designed for easy installation. Available for input currents up to 180A and nominal voltages up to 480VAC.

Features

True Power Measurement

- Measures true power (HP or kW) on balanced loads; accounts for voltage and power factor fluctuations and improves sensitivity to load changes.
- Requires only one or two power legs for installation.

Fast and Easy Installation

- Current and voltage sensors in one package and 24VDC loop-powered supply allows for quick and easy two-wire installation.

Field Adjustable Setpoint Ranges

- Jumper-selectable input range allows users to tailor input to the application for more precise control.

Dimensions

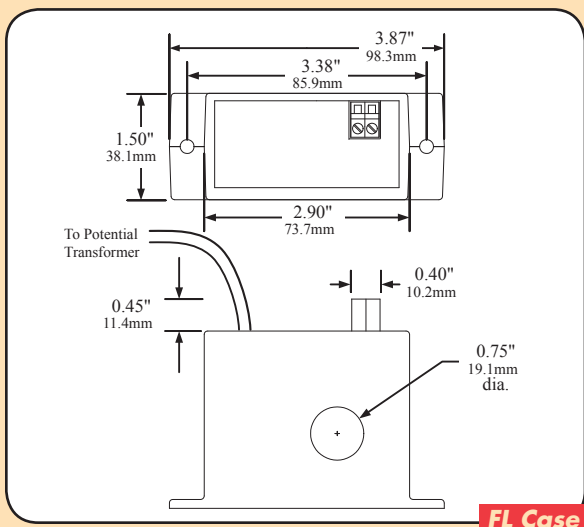

Connections

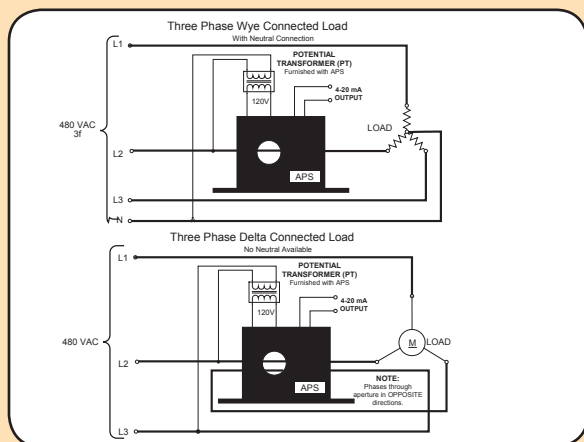
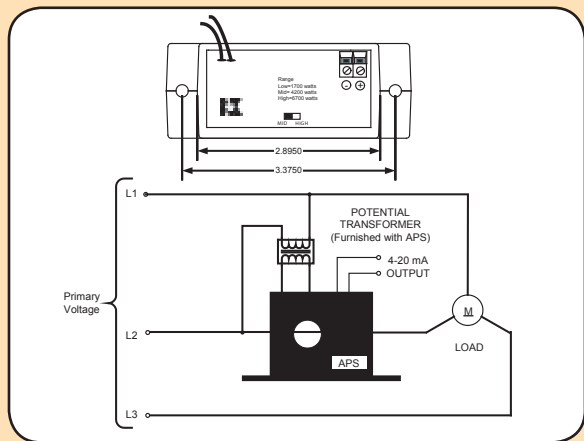

Wiring Notes For Three Phase Delta loads

1. Connect two phases to the Potential Transformer (PT).
2. Bring one of the PT connected phases through the sensor aperture.
3. Bring the other phase through the sensor aperture in the opposite direction.

Specifications

Power Supply	24VDC Nominal Loop Powered (40VDC Max.)
Output	4–20mA Proportional to max kW; 25mA Limit
Input Range(s)	120, 240 or 480VAC Nominal, +/- 25%
Potential Transformer	Pre-wired to APS, 18 AWG 28", flange mounting
Response Time	100 ms (to 90% of step change)
Accuracy	1% FS
Indication	Power on LED
Max Inrush Current	300% Full Scale Range (6 sec. duration)
Max. Power Output	0.2 KW to 110 KW; 1/4 HP @ 120VAC to 150 HP @ 480VAC
Frequency Range	50–60 Hz
Case	UL94 V0 Flammability Rated
Environmental	-4 to 122°F (-20 to 50°C), 0–95% RH non-condensing

Ordering Information

Sample Model Number: APS1-48T-420-24L-FL

Single phase watt transducer, 2, 5, & 8 Amp ranges, 480VAC input, may be wired with two opposite current wire passes, 4–20mA output, loop powered.

APS (1) - (2) - (3) - (4) - (5)

(1) Input Amps

1	2, 5, 8 Amps
2	12, 18, 25 Amps
3	40, 60, 80 Amps

(4) Power Supply

24L	24VDC Loop-powered
-----	--------------------

(5) Case Style

FL	Solid-core
----	------------

(2) Voltage Input*

12S or 12T	120VAC
24S or 24T	240VAC
48S or 48T	480VAC

(3) Output Signal

420	4–20mA
-----	--------

*Note: S Series: Solid-core single current pass
T Series: Solid-core, two opposite current passes