



MADE IN USA

APT Series power transducers sense true, "active" power and are a cost-effective way to measure kW on 1 ϕ or 3 ϕ applications up to 600VAC. Powered by 24V or 120V supply, the APT provides a fully isolated 4–20mA proportional output making it compatible with most supervisory controllers, panel meters and data loggers. Housed in a compact, DIN-compatible enclosure, the APT accepts standard 5A or 0–333mV current transformer inputs. Optional accessories include transceivers for wireless communication.

Features

- **4–20mA Proportional Output to kW; Compatible with PLC and Datalogging Equipment**
- **Accepts 5A Secondary CTs or 0–333mV ProteCT™ CTs**
- **DIN-rail Compatible Package; Finger-safe Terminals**

Applications

True, Active Power Monitoring

- Measure motor power consumption when current alone provides insufficient resolution (e.g. voltage or PF variation).
- Monitor machine tool finishing operations such as deburring.
- Sense brush entanglements in carwash systems.
- Detect dry run or blockages on pumping systems.
- Monitor SCR fired electrical heaters.
- Monitor general power usage and tripping of electrical loads.

APT SERIES Power Transducers

Specifications

Power Supply	120VAC or 24VAC/VDC (+/- 10%), 2VA max
Output	0–5VDC, 0–10VDC or 4–20mA
Accuracy	0.5% Full Scale (True RMS KW)
Voltage Range	120–600VAC
Frequency Range	6–400Hz
Amperage Range	<ul style="list-style-type: none"> • 5A–4,000A w/standard 5A secondary CTs • 5A–1,500A w/ProteCT™ 333mV CTs
Indication	Power on LED
Mounting	DIN-rail Compatible
Pwr Consumption	<2.0VA
Isolated Voltage	1250VAC
EMC	EN50081-1, EN61000-6-2
Case	UL94 V0 Flammability Rated
Environmental	-4 to 122°F (-20 to 50°C), 0–95% RH non-condensing
Connections	CTs (3), Voltage Inputs (3), Output (two-wire) Wireless Mesh Network Transceiver (optional)

Ordering Information

Sample Model Number: APT-48T-5A-120-010



(1) Voltage (2) CT Inputs (3) Supply Voltage (4) Full Scale Output

12T	120V Three Phase	5A	XXX:5 5A Secondary	024	24VAC	005	0–5VDC
24T	240V Three Phase	MV	XXX:333mV Secondary	120	120VAC	010	0–10VDC
48T	480V Three Phase					420	4–20mA

Pump Motor KW Monitoring

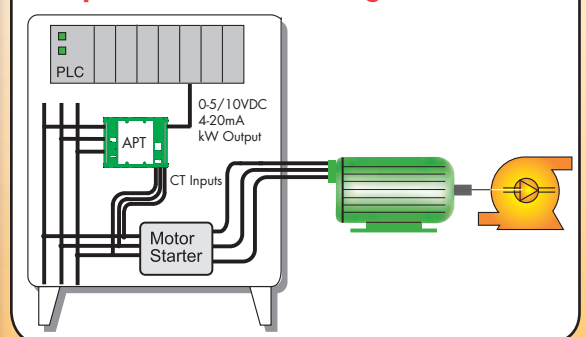

Dimensions

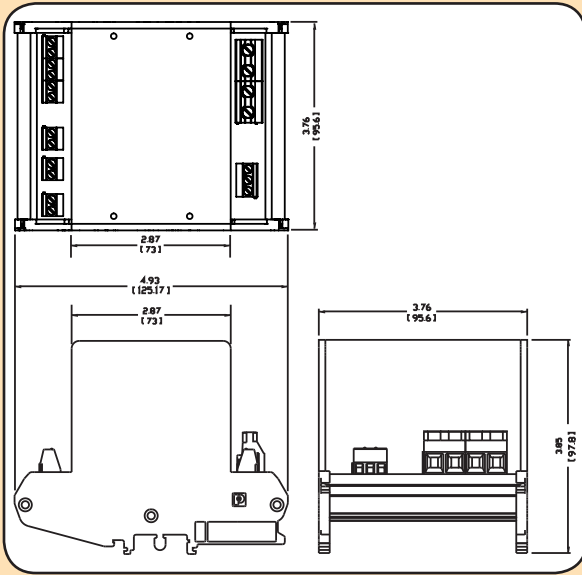

Connections

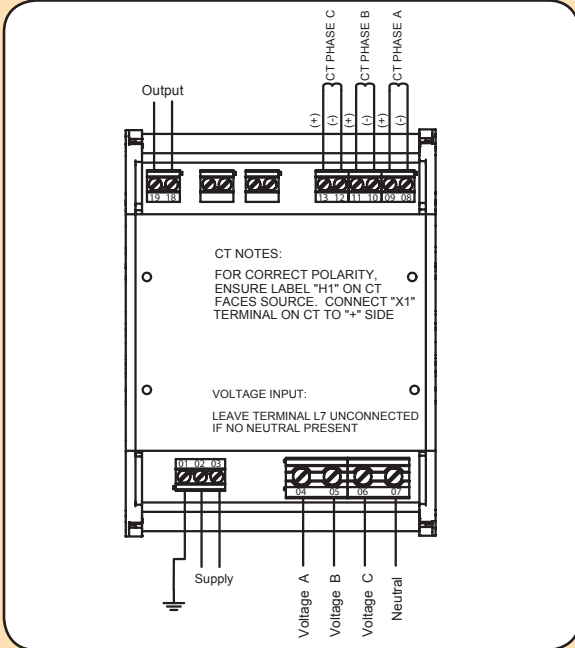

APT Output Values

Voltage	CT Ratio	Full Scale kW (20mA)
480	5:5	4.16
480	100	83.14
480	200	166.28
480	400	332.55
480	600	498.83
480	800	665.11
480	1000	831.38
480	1200	997.66
480	1500	1247.08
480	1600	1330.22
480	2000	1662.77
380	5:5	32.91
380	100	65.82
380	200	131.64
380	400	263.27
380	600	394.91
380	800	526.54
380	1000	658.18
380	1200	789.82
380	1500	987.27
380	1600	1053.09
380	2000	1316.36
240	5:5	2.08
240	100	41.57
240	200	83.19
240	400	166.28
240	600	249.42
240	800	332.55
240	1000	415.69
240	1200	498.83
240	1500	623.54
240	1600	665.11
240	2000	831.38
208	5:5	1.81
208	100	36.03
208	200	72.05
208	400	144.11
208	600	216.16
208	800	288.21
208	1000	360.27
208	1200	432.32
208	1500	540.40
208	1600	576.43
208	2000	720.53
120	5:5	1.04
120	100	20.79
120	200	41.57
120	400	83.14
120	600	124.71
120	800	166.28
120	1000	207.85
120	1200	249.42
120	1500	311.77
120	1600	332.55
120	2000	415.69