



MADE IN USA

**ATP/ATPR 3 & 4 Series** Powered High-Current Transducers are large-format solid-core transducers designed for high current applications from 200A to 2000A. Powered by 120VAC or 24VAC/VDC, these products take advantage of available power supplies and eliminate the need for costly control power transformers. Options include average responding and True RMS versions, 0-5/10VDC or 4-20mA analog outputs and switch-selectable input ranges.

## ATP/ATPR 3 & 4 SERIES Current Transducers

### Applications

#### Commercial and Industrial MCC's

- Fits conveniently in motor control centers, senses current on industrial motors and provides analog inputs back to PLC or controller.

#### VFD or SCR Controlled Loads, Electronic Ballasts

- Helpful in monitoring VFD-controlled motors to provide operational status. ATR Series also provides accurate measurement of ballast input power and phase angle fired SCRs.

#### Large Pumping Applications

- Ideal for proof-of-flow in water/wastewater, boiler and other industrial pumping applications 150 HP and over. 120VAC or 24VAC/VDC supply options allow for powering off of readily available supply, eliminating need for CPTs.

#### Power Distribution Centers (PDCs)

- Monitors current output on commercial generation equipment and serves as a current input for use in power consumption calculations.

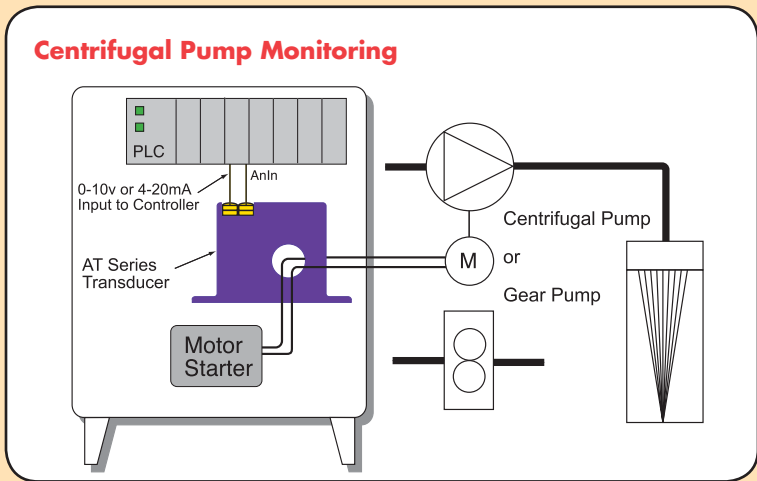

### Features

#### Large Aperture

- Accommodates large conductors or wire bundles.

#### Select the Right Output

- True RMS technology is accurate on distorted wave form like those associated with VFD or SCR outputs.
- Average Responding for use with linear, sinusoidal waveforms.

#### Jumper Selectable Ranges

- Reduces inventory.
- Eliminates zero and span pots.

#### Isolation

- Output is magnetically isolated from the input for safety.
- Eliminates insertion loss (voltage drop).

## Dimensions

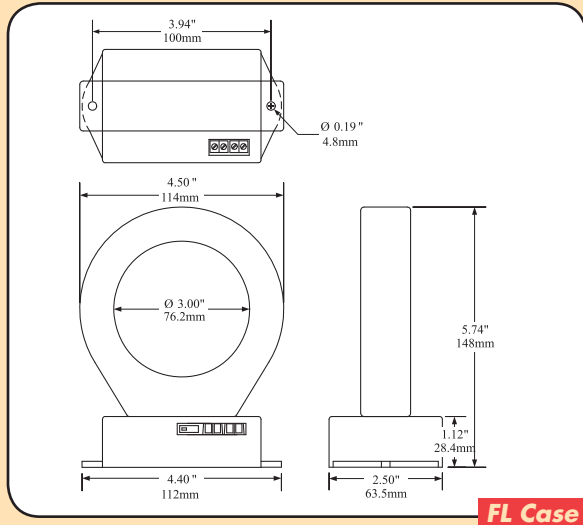

## Connections

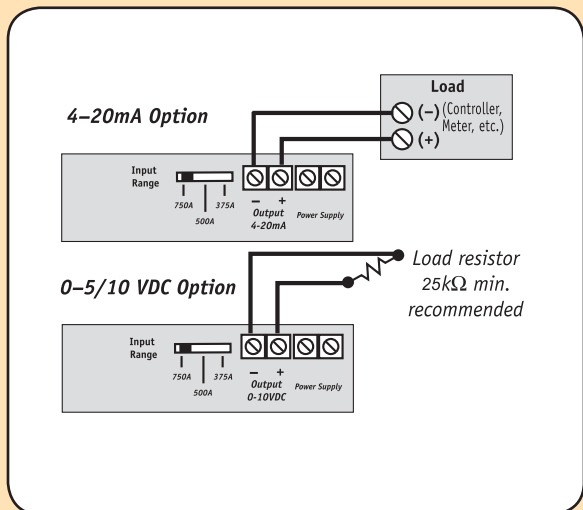

**Notes:** Terminals are deadfront captive screw terminals.  
 Use 12-22 AWG solid or stranded.

## Specifications

Model	-005 Model	-010 Model	-420Model
<b>Output Signal</b>	0-5VDC	0-10VDC	4-20mA
<b>Output Limit</b>	112% (5.6V)	112% (11.2V)	112% (22.4mA)
<b>Loading</b>	25KΩ min.: VDC Models 500Ω max.: 4-20mA Models		
<b>Response Time</b>	100ms (10-90% step change)		
<b>Frequency Range</b>	<ul style="list-style-type: none"> <li>● ATP: 40-100Hz, Sinusoidal</li> <li>● ATPR: 10-400Hz</li> </ul>		
<b>Accuracy</b>	1.0% FS		
<b>Power Supply</b>	120VAC or 24VAC/VDC, 2VA max		
<b>Isolation Voltage</b>	600VAC		
<b>Input Ranges (switch selectable)</b>	<ul style="list-style-type: none"> <li>● ATP3/ATPR3: 0-375A/500A/750A</li> <li>● ATP4/ATPR4: 0-1000A/1333A/2000A</li> </ul>		
<b>Sensing Aperture</b>	3.0" (76.2mm) dia.		
<b>Case</b>	UL94 V0 Flammability Rated		
<b>Environmental</b>	5 to 122°F (-15 to 50°C) 0-95% RH, non-condensing		

## Ordering Information

Sample Model Number: ATPR3-420-120-FL  
 True RMS AC current transducer, 24VDC, powered with a 4-20mA output, 375/500/750A ranges in a fixed core case.

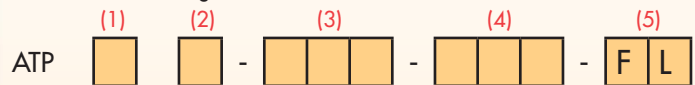

(1) Measurement

R	True RMS
	Average Responding (Blank)

(5) Case Style

FL	Solid-core
----	------------

(2) Full Scale Range

3	375-750A
4	1000-2000A

(3) Output Signal

005	0-5VDC
010	0-10VDC
420	4-20mA

(4) Power Supply

24U	24VAC/DC
120	120VAC