



AT/ATR 3 & 4 SERIES Current Transducers

Applications

Large Pumps

- Detect dry run electronically.

Power Generation

- Measure the output of generators.

Electric Heating Elements

- Monitors heater loads.
- Faster response than temperature sensors.

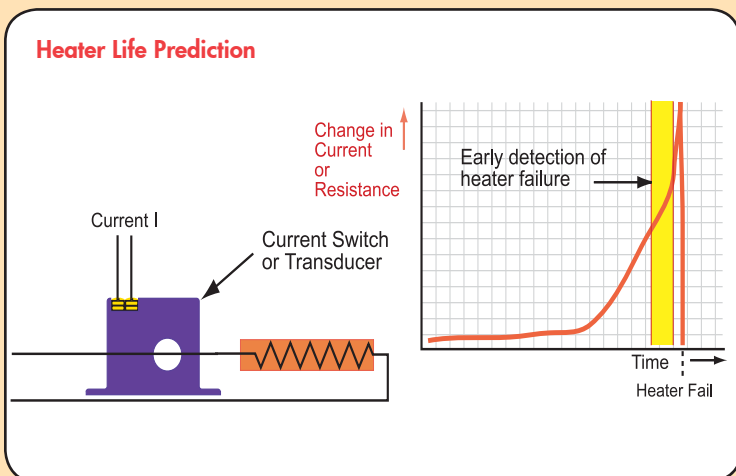

AT/ATR 3 & 4 Series Current Transducers combine a current transformer and a signal conditioner into a single package for applications from 200A to 2000A. The AT version is Average Responding for use on linear (sinusoidal) loads. The ATR version is True RMS for use on distorted waveforms found in VFD or SCR outputs. Available in a solid-core case.

Features

Large Aperture

- Accommodates large conductors or wire bundles.

Select the Right Output

- True RMS technology is accurate on distorted waveform like those associated with VFD or SCR outputs.
- Average Responding for use with linear, sinusoidal waveforms.

Jumper Selectable Ranges

- Reduces inventory.
- Eliminates zero and span pots.

Isolation

- Output is magnetically isolated from the input for safety.
- Eliminates insertion loss (voltage drop).

Agency Approved

- UL, CUL approved.

Selecting the right transducer:

The current waveform of a typical linear load is a pure sine wave. AT transducers measure the peaks of these sine waves, then calculate the average amperage. This works well on constant speed linear loads in "clean" power environments. **Select AT transducers for strictly linear loads on "clean" power.**

VFD and SCR output waveforms are rough approximations of a sine wave. There are numerous spikes and dips in a mathematical algorithm called "True RMS," which integrates the actual waveform over time. The output is the amperage component of the true power (heating value) of the AC current waveform. True RMS is the only way to accurately measure distorted AC waveforms. **Select ATR transducers for nonlinear loads on "noisy power."**

Dimensions

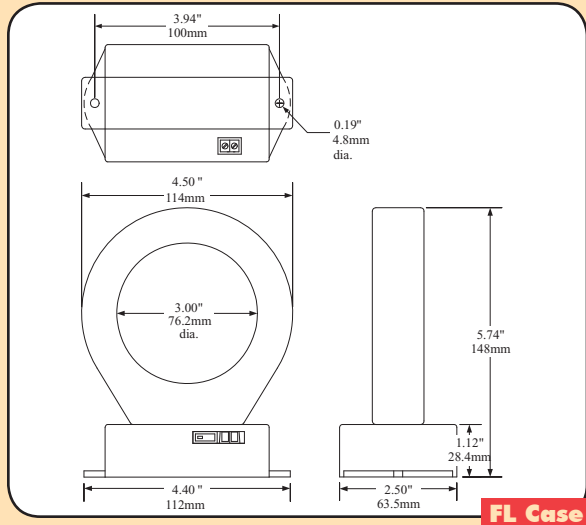

FL Case

Connections

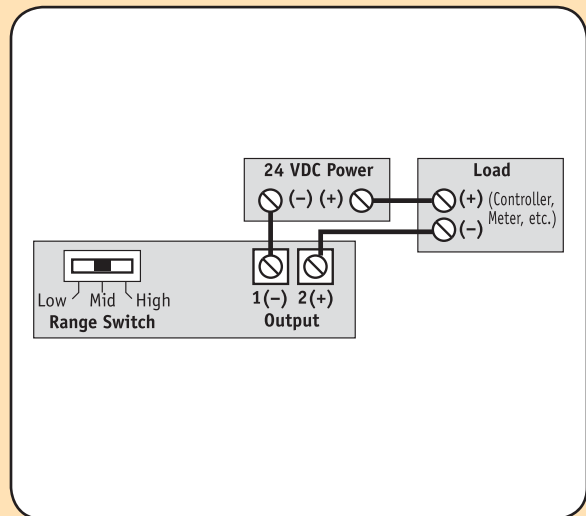

Notes: Deadfront captive screw terminals.
 12-22 AWG solid or stranded.
 Observe polarity.

Specifications

Output Signal	4–20mA, Loop-powered
Output Limit	23mA
Accuracy	1.0% FS accuracy, True RMS
Measurement	True RMS or Average Responding (See Ordering Information)
Response Time	600 ms (to 90% step change)
Frequency Range	<ul style="list-style-type: none"> ● ATR: 10–400Hz ● AT: 50–60Hz, Sinusoidal
Power Supply	24VDC Nominal, 40VDC Maximum
Isolation Voltage	600VAC
Input Ranges	<ul style="list-style-type: none"> ● AT/ATR3: 375, 500, 750A ● AT/ATR4: 1000, 1333, 2000A
Sensing Aperture	3.0" (76.2mm) dia.
Case	UL94 V0 Flammability Rated
Environmental	-4 to 122°F (-20 to 50°C) 0–95% RH, non-condensing
Listings	CE, UL 508 Industrial Control Equipment



Ordering Information

Sample Model Number: ATR3-420-24L-FL

True RMS AC current transducer, 24VDC, powered with a 4–20mA output, 375/500/750A ranges in a solid-core case.

AT (1) (2) - 4 2 0 - 2 4 L - F L

(1) Measurement

R	True RMS
	Average Responding (Blank)

(2) Full Scale Range

3	375, 500, 750A
4	1000, 1333, 2000A

(3) Output Signal

420	4–20mA
-----	--------

(4) Power Supply

24L	24VDC Loop-powered
-----	--------------------

(5) Case Style

FL	Solid-core
----	------------