

HMT330 Series Humidity and Temperature Transmitters for Industrial Applications



Features/Benefits

- Six models for demanding industrial applications
- Full 0 ... 100 % RH measurement, temperature range up to +180 °C (+356 °F), depending on model
- Pressure tolerance up to 100 bar (depending on model)
- Vaisala HUMICAP® Sensor for excellent accuracy and stability
 - Next generation sensor available
- Graphical display of measurement trends and over four-year history
- Multilingual user interface
- Excellent performance in harsh chemical concentrations
- Corrosion resistant IP65 housing
- NIST traceable (certificate included)

The HMT330 transmitter family has the solution for demanding industrial humidity measurements.

The Vaisala HUMICAP® Humidity and Temperature Transmitter Series HMT330 is designed for demanding industrial applications where stable measurement and wide customization is important.

Vaisala HUMICAP® performance

The HMT330 series incorporates Vaisala's 30 years of experience in industrial humidity measurement. Next to the proven reliable and accurate HUMICAP® sensor, an updated, even more stable and chemical resistant sensor is available.

Chemical purge minimizes effects of contaminants

In environments with high concentrations of chemicals and cleaning agents, chemical purge helps to maintain measurement accuracy between calibration intervals.

Chemical purge involves heating the sensor to remove harmful chemicals. The function can be initiated manually or programmed to occur at set intervals.

Graphical display of history and measurement trends

The HMT330 can be ordered with a large numerical and graphical display, which allows the user to clearly monitor operational data, measurement trends and 1-year measurement history. The optional data logger with real-time clock makes it possible to generate over four years of measured history, and zoom in on any desired time or time frame. The battery backup of the clock guarantees a reliable logging of measured data.

Data collection and transfer to PC

The recorded measurement data can be viewed on the display or transferred to a PC with Microsoft Windows® software. A USB-RJ45 cable makes it easy to connect the service port of the HMT330 to a PC.

Many ways to install and versatile outputs

Mains and DC power options, and several mounting accessories make the instrument easy to install. The HMT330 can have up to three

analog outputs. Isolated galvanic power supply and analog outputs are also available. For serial interface the USB connection, RS232 and RS485 can be used.

Flexible calibration

The HMT330 instruments are calibrated at six humidity points at the factory. A quick, one-point field calibration can be performed with the hand-held HM70 meter. A two-point calibration can be performed with the HMK15 salt bath calibrator in a controlled environment. The transmitter can be sent to Vaisala for recalibration. Accredited calibrations and maintenance contracts are also available.

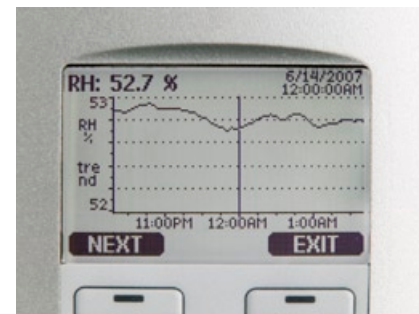

The display shows measurement trends, real time data and over four years history.

Performance

Relative humidity	
Measurement range	0 ... 100 % RH
Accuracy (including non-linearity, hysteresis, and repeatability)	for typical applications
with Vaisala HUMICAP® 180 or 180R	for applications with
with Vaisala HUMICAP® 180C or 180RC	chemical purge/warmed probe
at +15 ... +25 °C (59 ... +77 °F)	±1 %RH (0 ... 90 %)
at -20 ... +40 °C (-4 ... +104 °F)	±1.7 %RH (90 ... 100 %RH)
at -40 ... +180 °C (-40 ... +356 °F)	±(1.0 + 0.008 x reading) %RH
with Vaisala HUMICAP® 180L2	for application with demanding
	chemical environment
at -10 ... +40 °C (14 ... +104 °F)	±(1.0 + 0.01 x reading) %RH
at -40 ... +180 °C (-40 ... +356 °F)	±(1.5 + 0.02 x reading) %RH
Factory calibration uncertainty (+20 °C)	± 0.6 % RH (0 ... 40 %RH)
	± 1.0 % RH (40 ... 97 %RH)
(Defined as ±2 standard deviation limits. Small variations possible, see also calibration certificate.)	
Response time (90 %) at +20 °C (+68 °F) in still air	8 s / 17 s* with grid filter
	20 s / 50 s* with grid + steel netting filter
	40 s / 60 s* with sintered filter

* with HUMICAP® 180R or 180RC sensor

Temperature

Measurement range	
HMT331	-40 ... +60 °C (-40 ... +140 °F)
HMT333	-40 ... +80 °C or -40 ... +120 °C
	(-40 ... +176 °F or -40 ... +248 °F)
HMT334, HMT335, HMT337,	
HMT338	-70 ... +180 °C (-94 ... +356 °F)
Accuracy at +20 °C (+68 °F)	± 0.2 °C (± 0.36 °F)
Accuracy over temperature range	

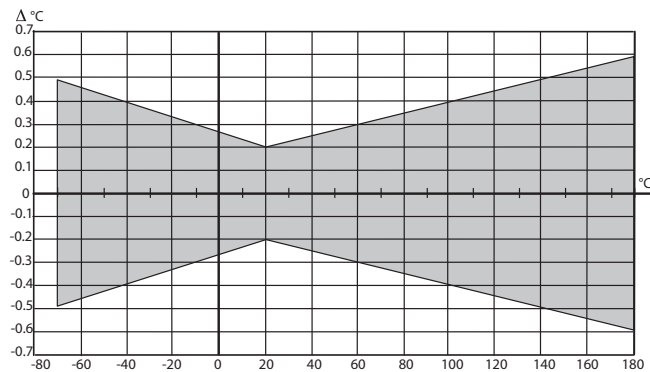

Temperature sensor PT 100 RTD 1/3 Class B IEC 751

Other variables available (depends on model)
dewpoint temperature, mixing ratio, absolute humidity, wet bulb temperature, enthalpy, water vapor pressure

Operating environment

Operating temperature	
for probe	same as measurement range
for transmitter body	-40 ... +60 °C (-40 ... 140 °F)
with display	0 ... +60 °C (32 ... 140 °F)
Operating pressure	
HMT334	0 ... 10 MPa (0 ... 100 bar)
HMT338	0 ... 4 MPa (0 ... 40 bar)
HMT335, HMT337	vapor tight
Electromagnetic compatibility	Complies with EMC standard EN61326-1, Industrial Environment

Inputs and outputs

Operating voltage	10 ... 35 VDC, 24 VAC
with optional power supply module	100 ... 240 VAC, 50/60 HZ
Power consumption at +20 °C (U _{in} 24 VDC)	
RS-232	max. 25 mA
U _{out} 2 x 0 ... 1 V/0 ... 5 V/0 ... 10 V	max. 25 mA
I _{out} 2 x 0 ... 20 mA	max. 60 mA
display and backlight	+ 20 mA
during chemical purge	max. 110 mA
during probe heating (HMT337)	+ 120 mA
Analog outputs (2 standard, 3rd optional)	
current output	0 ... 20 mA, 4 ... 20 mA
voltage output	0...1 V, 0...5 V, 0...10 V
Accuracy of analog outputs at +20 °C	±0.05% full scale
Temperature dependence of the analog outputs	±0.005%/°C full scale
External loads	
current outputs	R _L < 500 ohm
0 ... 1 V output	R _L > 2 kohm
0 ... 5 V and 0 ... 10 V outputs	R _L > 10 kohm
Max. wire size	0.5 mm ₂ (AWG 20)
	stranded wires recommended
Digital outputs	RS-232, RS-485 (optional)
Service connection	RS-232, USB
Relay outputs (optional)	0.5 A, 250 VAC
Optional data logger with real-time clock	
Logged parameters	max. three with trend/min/max values
Logging interval	10 sec (fixed)
Max. logging period	4 years 5 months
Logged points	13.7 million points per parameter
Battery lifetime	min. 5 years
Display	LCD with backlight, graphic trend display of any parameter
Menu languages	English, Chinese, Japanese, Spanish, German, French, Swedish, Russian, Finnish

Mechanics

Cable bushing	M20 x 1.5 for cable diameter
	8 ... 11 mm/0.31 ... 0.43"
Conduit fitting	1/2" NPT
User cable connector (optional)	M12 series 8-pin (male)
option 1	female plug with 5 m (16.4 ft) black cable
option 2	female plug with screw terminals
Probe cable diameter	
HMT333 (+80 °C)	6.0 mm
other probes	5.5 mm
Housing material	G-ALSi 10 Mg (DIN 1725)
Housing classification	IP 65 (NEMA 4)

Dimensions

dimensions in mm (inches)

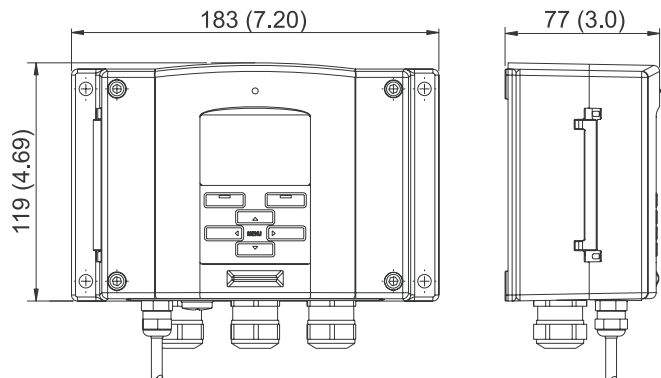

HUMICAP® is a registered trademark of Vaisala.
Specifications are subject to change without prior notice.
©Vaisala Oyj



HMT331 Humidity and Temperature Transmitter for Demanding Wall-Mounted Applications



Features/Benefits

- For temperatures -40 ... +60 °C (-40 ... +140 °F)
- Vaisala HUMICAP® Sensor for excellent accuracy and stability
- High tolerance of chemicals
- Graphical display of measurement trends and over four-year history
- Corrosion resistant metal IP65 housing
- NIST traceable (certificate included)
- Application examples: cleanrooms, pharmaceutical processes, greenhouses, swimming halls, museums and archives

The HMT331 is the state-of-the-art wall-mount humidity instrument.

The Vaisala HUMICAP® Humidity and Temperature Transmitter HMT331 is the top-of-the-line wall-mounted transmitter for demanding HVAC and condition monitoring applications.

Compared to regular wall-mounted transmitters, the HMT331 offers:

- Higher measurement performance
- Better chemical tolerance
- Advanced graphical display features
- More powering options
- More output options
- A wider variety of output humidity parameters

Graphical display of history and measurement trends

The HMT330 series features a large numerical and graphical display, allowing users to easily monitor operational data, measurement trends and one-year measurement history. The optional data logger with real-time clock makes it possible to generate over four years of measured history, and zoom in on any desired time or time frame.

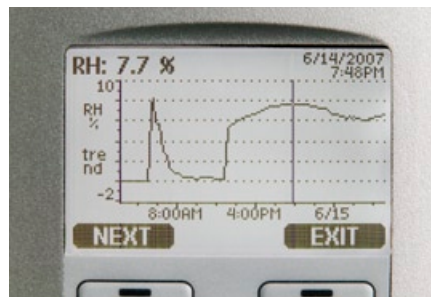

The display shows measurement trends over four-year real time measurement history.

The battery backup of the real-time clock guarantees a reliable logging of measured data.

Outputs and power supply options for every need

The output options include three analog outputs, RS-232, RS-485, and alarm relays.

The voltage supply range is from 10 to 35 VDC. With an additional module, the transmitter can be connected to all universal mains AC supplies. The input/output cable can be fed through the back of the transmitter, which is a useful feature, especially for installations in cleanrooms.

Technical Data

Temperature measurement range
 -40 ... +60 °C (-40 ... +140 °F)

Accessories

PC software + cable	215005
USB-RJ45 Serial Connection Cable	219685
Connection cable for HM70	211339
Wall mounting plate (plastic)	214829
Pole installation kit	215108
Rain shield	215109
DIN rail installation set	215094

Dimensions

Dimensions in mm (inches)

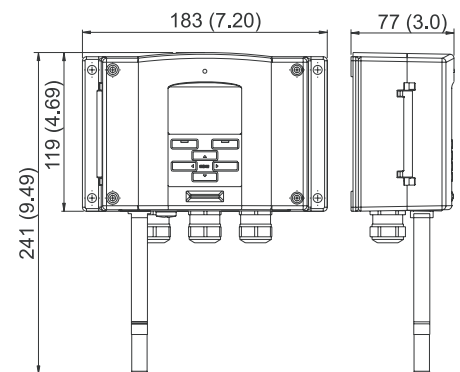

HMT333 Humidity and Temperature Transmitter for Ducts and Tight Spaces

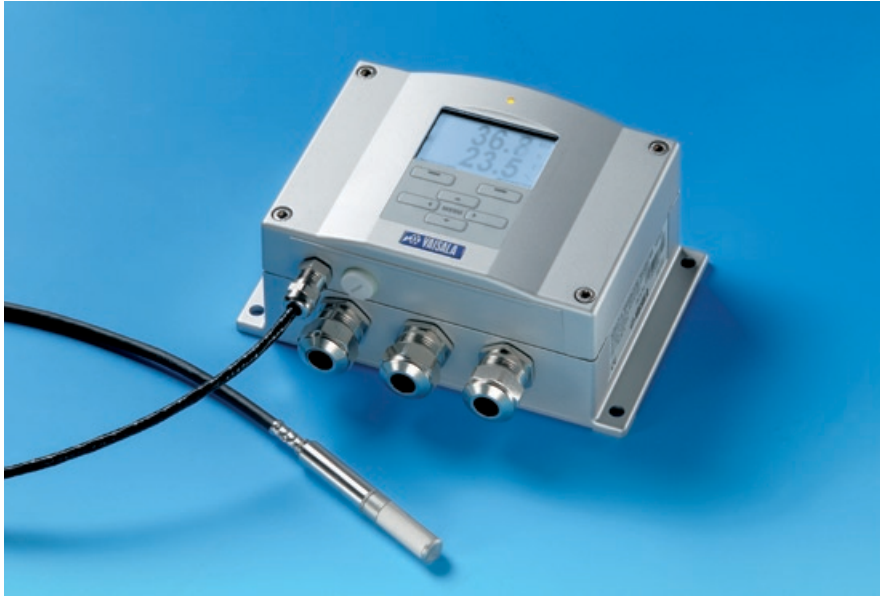

The HMT333 transmitter has a small probe for remote applications.

Features/Benefits

- For remote probe installations in demanding HVAC applications
- Vaisala HUMICAP® Sensor for excellent accuracy and stability
- High tolerance of chemicals
- For temperatures -40 ... +80 °C (-40 ... +176 °F) or -40 ... +120 °C (-40 ... +248 °F)
- Small thermal mass - fast response to temperature changes
- Graphical display of measurement trends and over four-year history
- Corrosion resistant IP65 housing
- NIST traceable (certificate included)
- Application examples: cleanrooms, pharmaceutical processes, greenhouses, environmental chambers

The Vaisala HUMICAP® Humidity and Temperature Transmitter HMT333 is a versatile instrument for applications where a small remote probe is needed.

Flexible installation

To install the probe in ducts, channels and through walls, an installation kit is available with an aluminum flange, lead-through piece, and steel support bar.

HMT333 has two probe cable options available, a flexible one that withstands heat up to +80° C, and a durable cable that withstands heat up to +120° C. Both cable options are available in lengths of 2, 5, and 10 meters.

For outdoor environments, the DTR502B solar radiation shield provides protection for the probe. The shield can be installed on a pole, a beam or a flat surface.

For moderate humidities and temperatures

The HMT333 is typically used in demanding HVAC applications such as cleanrooms, pharmaceutical processes, and greenhouses, or in processes of moderate temperature.

For environments with continuously high humidity, the HMT337 with a warmed, vapor-tight and stainless steel probe is recommended.

Technical Data

Temperature measurement range	-40 ... +80 °C (-40 ... +176 °F) or -40 ... +120 °C (-40 ... +248 °F)
-------------------------------	--

Accessories

Duct installation kit	210697
Cable gland	HMP247CG
PC software + cable	215005
USB-RJ45 Serial Connection Cable	219685
Connection cable for HM70	211339
Wall mounting plate (plastic)	214829
Pole installation kit	215108
Rain shield	215109
Solar radiation shield	DTR502B
DIN rail installation set	215094

Dimensions

Dimensions in mm (inches) below

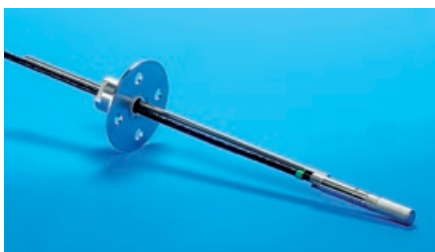
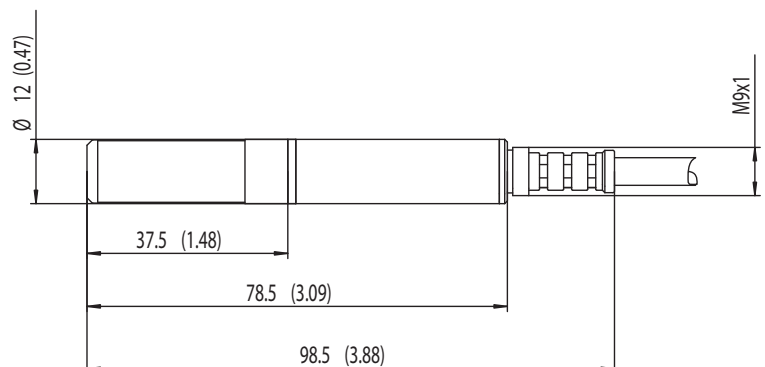

Duct installation kit

HMT334 Humidity and Temperature Transmitter for High Pressure and Vacuum Applications



Features/Benefits

- For pressures up to 100 bar and vacuum applications
- For temperatures -70 ... +180 °C (-94 ... +356 °F)
- ISO and NPT threads available
- Vaisala HUMICAP® Sensor for excellent accuracy and stability
- Graphical display of measurement trends and over four-year history
- Corrosion resistant IP65 housing
- NIST traceable (certificate included)
- Application example: test chambers

The HMT334 is ideal for permanent installations into pressurized or vacuum processes.

The Vaisala HUMICAP® Humidity and Temperature Transmitter HMT334 is designed to measure humidity in pressurized spaces or vacuum chambers. Each probe is tested to ensure a gas and vacuum tight installation.

Vaisala HUMICAP® performance

The HMT334 incorporates Vaisala's more than 30 years of experience in industrial humidity measurement. The sensor provides accurate and reliable measurement and is immune to particulate contamination and most chemicals.

Graphical display of measurement trends and real time history

The HMT330 series features a numerical and graphical display. The user can easily monitor operational data, measurement trends and up to one-year history. The optional data logger with real-time clock makes it possible to generate more than four years of measured history, and zoom in on any desired time or time frame.

Using a serial line, the measurement data can be transferred to a PC where it can be further processed and copied to other programs.

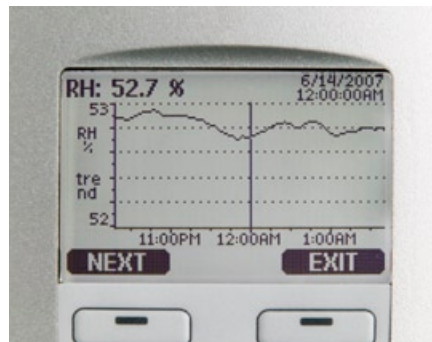

The display shows measurement trends and over four-year real time measurement history.

Technical Data

Temperature measurement range	-70 ... +180 °C (-94 ... +356 °F)
Operating pressure	0 ... 10 MPa (0 ... 100 bar)

Accessories

Fitting body ISO M22 x 1.5	17223
Fitting body NPT 1/2"	17225
PC software + cable	215005
USB-RJ45 Serial Connection Cable	219685
Connection cable for HM70	211339
Wall mounting plate (plastic)	214829
Pole installation kit	215108
Rain shield	215109
DIN rail installation set	215094

Dimensions

Dimensions in mm (inches)

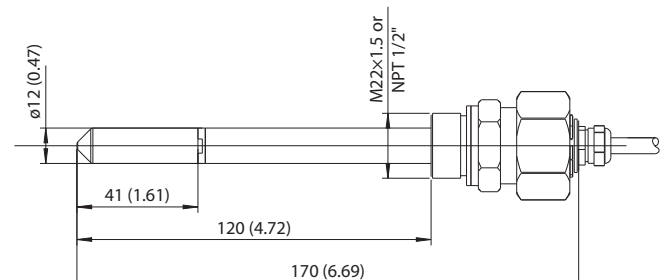

HMT335 Humidity and Temperature Transmitter for High Temperatures



Features/Benefits

- For temperatures -70 ... +180 °C (-94 ... +356 °F)
- Long metal probe head
- Stainless steel installation flange available
- Adjustable installation depth
- Vaisala HUMICAP® Sensor for excellent accuracy and stability
- Graphical display of measurement trends and over four-year history
- Corrosion resistant IP65 housing
- NIST traceable (certificate included)
- Application example: hot drying processes

The HMT335 has a robust stainless steel probe ideal for high flow rates in hot processes.

The Vaisala HUMICAP® Humidity and Temperature Transmitter HMT335 has a long stainless steel probe designed for high temperatures.

Robust probe ideal for high flow rates

The HMT335 is ideal for duct measurements as the probe tolerates mechanical stress and withstands high flow rates. The HMT335 can be used, for example, in a hot drying process.



The installation flange allows an adjustable installation depth for the probe.

Graphical display of history and measurement trends

The HMT335 features a numerical and graphical display. The user can easily monitor measurement operational data, measurement trends and one-year measurement history.

The optional data logger with real-time clock makes it possible to generate more than four years of measured history, and zoom in on any desired time or time frame.

Vaisala HUMICAP® performance

The sensor provides accurate and reliable measurement and is immune to particulate contamination and most chemicals.

Technical Data

Temperature measurement range	-70 ... +180 °C (-94 ... +356 °F)
-------------------------------	-----------------------------------

Accessories

Mounting flange	210696
PC software + cable	215005
USB-RJ45 Serial Connection Cable	219685
Connection cable for HM70	211339
Wall mounting plate (plastic)	214829
Pole installation kit	215108
Rain shield	215109
DIN rail installation set	215094

Dimensions

Dimensions in mm (inches)

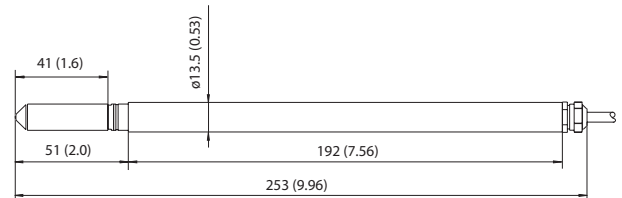

HMT337 Humidity and Temperature Transmitter for High Humidity Applications



The HMT337 is the ideal transmitter for the most demanding process and meteorological measurements.

Features/Benefits

- For high-humidity applications in industry and meteorology
- Warmed probe for superior performance in condensing environments
- Small, stainless steel, vapor-tight remote probe
- For temperatures -70 ... +180 °C (-94 ... +356 °F)
- Vaisala HUMICAP® Sensor for excellent accuracy and stability
- High tolerance of chemicals
- Graphical display of measurement trends and over four-year history
- Corrosion resistant IP65 housing
- NIST traceable (certificate included)

The Vaisala HUMICAP® Humidity and Temperature Transmitter HMT337 is delivered in one of three configurations:

- Basic: non-warmed probe for moderate humidities
- With a warmed probe: for near-condensing conditions and dew point measurement
- With a warmed probe and an additional temperature sensor: for near-condensing conditions and relative humidity measurement

True humidity readings in conditions of condensation

The Vaisala unique warmed probe provides fast and reliable measurement in environments where humidity is near saturation. The warming prevents condensation from forming on the sensor.

As the probe is warmed, the humidity level inside it stays below the ambient level. With accurate temperature measurement, the ambient dewpoint can be calculated precisely.

If the relative humidity value is needed, an additional temperature sensor is used. The measured ambient temperature provides the compensation for calculating relative humidity and other humidity parameters.

Many ways to install

A tight installation through a process wall can be achieved with Swagelok® fittings. Meteorological installation kits for outdoor installations and duct installation kits are also available.



Duct installation kit



Technical Data

Temperature measurement range
 -70 ... +180 °C (-94 ... +356 °F)

Accessories

Cable gland and AGRO	HMP247CG
Duct installation kit (RH probe)	210697
Duct installation kit (T probe)	215003
Swagelok fittings (NPT and ISO) for both RH and T probes	
Solar radiation shield	DTR502B
Meteorological inst. kit	HMT330MIK
PC software + cable	215005
USB-RJ45 Serial Connection Cable	219685
Connection cable for HM70	211339
Wall mounting plate (plastic)	214829
Pole installation kit	215108
Rain shield	215109
DIN rail installation set	215094

Dimensions

Dimensions in mm (inches)

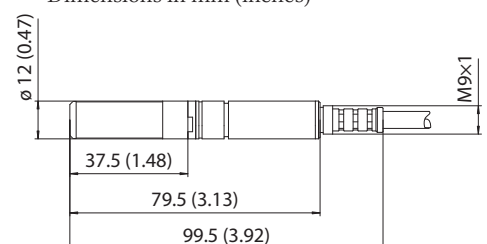

HMT338 Humidity and Temperature Transmitter for Pressurized Pipelines



The HMT338 is ideal for installations in pressurized processes where the probe needs to be removed while the process is running.

Features/Benefits

- Installed through ball valve
- can be inserted and removed while the process is running
- Adjustable probe depth
- Pressure tolerance 40 bar
- For temperatures -70 ... +180 °C (-94 ... +356 °F)
- Vaisala HUMICAP® Sensor for excellent accuracy and stability
- Graphical display of measurement trends and over four-year history
- Corrosion resistant IP65 housing
- Two probe lengths available
- NIST traceable (certificate included)

The Vaisala HUMICAP® Humidity and Temperature Transmitter HMT338 is designed for pressurized processes.

Insert or remove probe while the process is running

With “hot tapping”, the probe is inserted directly into the process while it is running, without the need for venting or lowering the process pressure.

The probe is screwed into a ball valve assembly that has been fixed to the process pipe or wall. The adjustable hex nut is hand-tightened to temporarily hold the probe to the process. Then the probe is pushed down to the appropriate depth. The hex nut is tightened with a wrench to lock the probe in its place. Hot tapping is possible in pressures up to 10 bar.

Graphical display of history and measurement trends

From the display, the user can easily monitor operational data, measurement trends and one-year measurement

history.

The optional data logger with real-time clock makes it possible to generate more than four years of measured history, and zoom in on any desired time or time frame. The battery backup of the real-time clock guarantees a reliable logging of measured data.

Vaisala HUMICAP®

The HMT338 incorporates Vaisala’s more than 30 years of experience in industrial humidity measurement. The sensor provides accurate and reliable measurement and is immune to particulate contamination and most chemicals.

Technical Data

Temperature measurement range	-70 ... +180 °C (-94 ... +356 °F)
Operating pressure	0 ... 4MPa (0 ... 40 bar)

Accessories

Ball valve set	BALLVALVE-1
Pressure fitting ISO 1/2 to NPT 1/2	210662
PC software + cable	215005
USB-RJ45 Serial Connection Cable	219685
Connection cable for HM70	211339
Wall mounting plate (plastic)	214829
Pole installation kit	215108
Rain shield	215109
DIN rail installation set	215094

Dimensions

Dimensions in mm (inches)

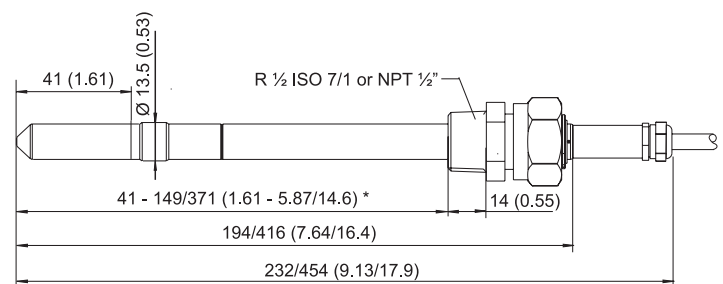

Lengths for standard / optional probes
 * freely user-adjustable length